

1 2 3 4 5 6

A

B

C

D

A

B

C

D

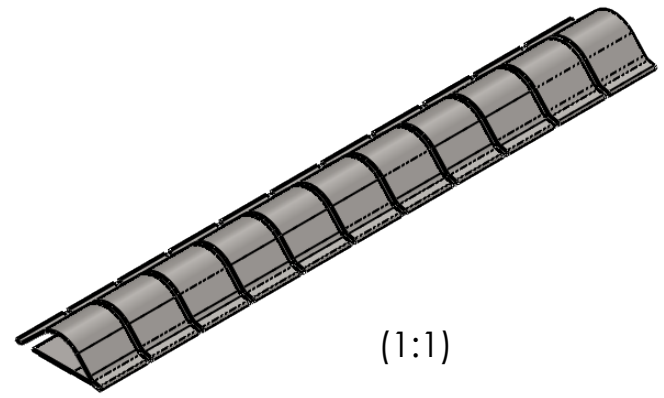
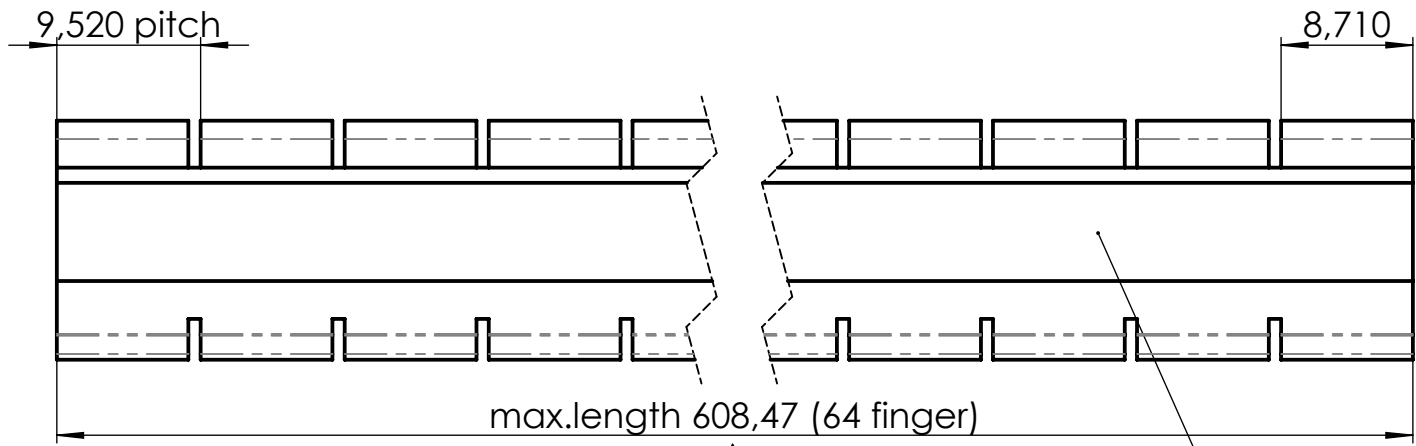

(1:1)

**drawing for customer information**

1

Stripes can be cut off after each finger on request.  
 Calculation of length in mm:  
 strip length = number of fingers x 1 pitch - 1 slot

<b>FEUERHERDT</b> EMI Shielding Products Specialist for Contact Springs		tolerances:	length tolerance:	dimensions in mm	scale: <b>2:1</b>	revision: <b>00</b>
		X,X ± 0,5 X,XX ± 0,2 X,XXX ± 0,1	100-300 ± 0,5 300-400 ± 0,8 400-500 ± 1 > 500 ± 1,5	unmeasured contours according to 3D data	material: <b>stainless steel 1.4310 X10CrNi18-8 F1100-1300</b>	
			date:	name:	description:	
			created 21.06.22	<b>Pröhl</b>	<h1>type V12</h1>	
			checked 21.06.22	<b>Akrim</b>		
			released			
			surface code:		drawing number:	
			bright finish -02 gold -03 silver -04	zink chromate/ clear -15 bright tin -17 bright nickel -19	<h1>CF.005.00.E</h1>	
rev.	description	date	name	thickness: t= <b>0,09</b>	replacement drawing:	
					sheet: 1	

1 2 3 4 5 6